

PRELIMINARY  
SPECIFICATIONS

MOVE THE WORLD FORWARD MITSUBISHI  
HEAVY  
INDUSTRIES  
GROUP

**EDiA EM**

**FB14-20(C)N2(T) Series**

# ELECTRIC COUNTERBALANCE

1.4 – 2.0 tonnes

**INTELLIGENT PERFORMANCE  
INCREDIBLE PRODUCTIVITY**

Smart. Safe. Agile. EDiA EM is a lot of truck in a compact package. Legendary Mitsubishi Forklift Trucks engineering, exceptional ergonomics, and cutting edge technology — like AutoBoost and Sensitive Drive System+ (SDS+) — combine to make EDiA a favourite of drivers and businesses alike.

## SPECIFICATIONS

FB14N2T	
FB16CN2T	FB16CN2
FB16N2T	FB16N2
FB18CN2T	FB18CN2
FB18N2T	FB18N2
FB20N2T	FB20N2



**WHEN  
RELIABILITY IS  
EVERYTHING...**

 **MITSUBISHI  
FORKLIFT TRUCKS**

# EDiA EM

## FB14-20(C)N2(T) Series

### ELECTRIC COUNTERBALANCE

1.4 – 2.0 tonnes



#### BRAKES

- **Electronic magnetic brakes**  
These don't rely on brake pads, eliminating associated maintenance and the risk of brake dust and contamination.
- **Intelligent Cornering System (ICS)**  
The truck senses the angle of a turn and reduces speed early for maximum stability and accurate, positive cornering.
- **Automatic parking brake with hill hold**  
The truck stops automatically when the accelerator is not engaged, preventing rolling on ramps. No need to remember to use a handle or switch.
- **Energy regen safety lights**  
When the truck is regenerating energy the truck slows down faster than usual when the throttle is released. Brake lights blink to warn traffic behind of the increased slow down.

#### DRIVE

- **AutoBoost**  
Acceleration and torque boost functions provide more power when needed, such as on ramps.
- **Sensitive Drive System+ (SDS+)**  
Our next-generation driver-assist system for increased safety. Traction and mast performance are independently managed according to steer angle and the velocity of foot and finger controls to match driver reaction speeds.

- **ECO mode**  
This mode optimises energy efficiency and gives smoother performance. Ideal for long shifts, training, new users, and part-time users.
- **PRO mode**  
This mode maximises performance parameters, giving full control to more experienced operators in intensive situations.
- **Electric differential lock**  
When activated, both front wheels spin simultaneously, giving the truck better traction and control in slippery conditions.

#### ELECTRICAL AND CONTROL SYSTEMS

- **Straightforward component layout**  
Fast, easy access to key areas, reducing downtime and cutting routine servicing bills.
- **Custom settings**  
Through the multi-functional configuration software TruckTool, the truck can be fine-tuned by a service engineer to meet any application or scenario.

#### FORKS AND MAST

- **Adaptive Lift Control (ALC)**  
Allows truck to remain stable with fewer movements when lowering loads from high heights.
- **Passive Sway Control (PSC)**  
Minimises mast sway, especially in high lifts above 3m.

- **Strong, high-visibility mast**  
Free-lift cylinder structure is optimised with hoses over chains for outstanding visibility.
- **High-durability hoses**  
Resistant to wear and wide-ranging temperatures — ensuring minimal downtime and disruption.

#### FRAME AND BODY

- **Bright LED working lights**  
Illuminate load and surroundings. Installed in mast structure, but do not light the structure or cabin to minimise reflections and increase visibility.
- **Sideways battery change**  
Integrated sliding rollers offer quick and easy battery change for multishift operations. (Option)
- **Safety Zone**  
Red lights are projected on the floor to the sides and rear of the truck to give nearby pedestrians a clear idea of the safe distance to keep.

#### HYDRAULICS

- **Precision tilt and side shift**  
This provides easy, fine control — making difficult movements safer and faster.
- **Load sensing hydraulic system**  
Load handling functions react similarly to different load weights.



For more information  
on EDiA EM  
please visit our website



mft2.eu/ediaem

# EDiA EM

## FB14-20(C)N2(T) Series

### ELECTRIC COUNTERBALANCE

1.4 – 2.0 tonnes



#### OPERATOR COMPARTMENT AND CONTROLS

- F2 button**  
 This simple thumb control integrates additional key controls without taking your eyes off the load. Options include clamp release and automatic tilt centring.
- Spacious, open cabin**  
 The room means that operators of various sizes can benefit from a range of comfortable driving positions.
- Unparalleled 360° visibility**  
 An optimised mast, wheel, dashboard and counterweight design maximises visibility to load, forks, front and rear wheels giving safe, confident operation in tight spaces.
- Optimised pedal position**  
 All pedals are in the most ergonomic position, shaped and angled so each pedal will feel familiar to use and easy on the ankles.
- Clear, informative display**  
 Full colour and easy to read from all angles, even in direct sunlight. Perfectly positioned for at-a-glance reference, without reducing all-round visibility.
- Highly responsive FeatherTouch steering**  
 Power to steering is automatically optimised for consistently smooth operations — regardless of speed or work intensity — for maximum control, comfort and safety.

- Highly responsive steering wheel**  
 Automatically optimises power to steering for consistently smooth operations — regardless of speed or work intensity — for maximum control, comfort and safety.
- Dual joysticks**  
 Dual joysticks offer simultaneous functions for lift and tilt, and settings can be customised to customer requirements. (Option)
- Multifunctional Ergologic Joystick**  
 This intuitive and highly ergonomic joystick controls seven different functions, including lifting, lowering, reaching and tilting.
- Long handle bar**  
 Aids safer entry/exit.
- Narrow inclined dashboard**  
 This enhances the driver's perception of surroundings — giving even greater visibility to the front and sides of the truck.
- Flat floor**  
 No obstructions and plenty of room for the operator.
- Extra-large low step**  
 Entry and exit is easy and safe, thanks to a high-grip surface.

#### STEERING SYSTEM

- 360-degree steering**  
 The operator can keep the truck in constant motion — saving seconds on every turn. (Option on 3-wheel models)
- Four Wheel Steering (4WS)**  
 Front axle drive motors turn in separate directions for better grip and precise handling. The rear axle steers through a full 100°, with dual drive motors for instant, smooth turning on the spot and no initial 'push'. This offers excellent manoeuvrability in tight spaces. (4-wheel models)
- Perfectly weighted steering**  
 Optimal steering wheel size with a light but firm feel gives confidence and manoeuvrability at all speeds.
- Mini steering wheel**  
 Allows operators to maintain a relaxed driving position and better view, ideal for longer shifts. (Option)

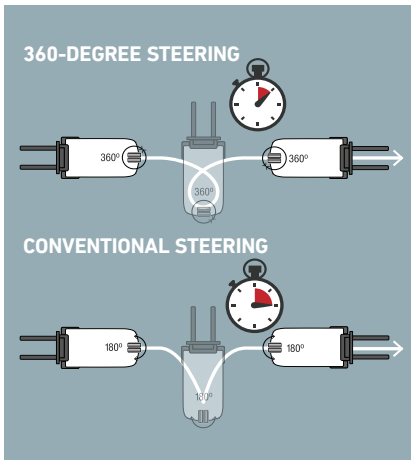

For more information on EDiA EM please visit our website





# EDIA EM OPTIONAL LI-ION BATTERY SYSTEMS

## MAKE YOUR FORKLIFT GO EVEN FURTHER



**Tried, tested and proven in the field, lead-acid batteries have been the long-standing choice for companies employing electric lift trucks. However, with long charging times, demanding maintenance requirements, the need for extra batteries, and high risk of operator misuse, day-to-day use can be a challenge.**

Fortunately, there's a new battery system on the block: Li-ion from Mitsubishi Forklift Trucks.

Designed to meet your business' demands — including multi-shift (24/7) operations — without the need for spare batteries, our high-performance Li-ion battery system is up to 30% more efficient than lead-acid counterparts. Plus, it's virtually error-proof, thanks to its ultra-low-maintenance design which prevents cell damage.

- **Gas-emission free and space efficient operation**  
with no need for air ventilation.



Li-ion battery option is available in selected regions.

Continuing improvement may lead to changes in these specifications

- **Exceptional high battery and charger efficiency**  
State-of-the-art technology delivers up to 30% more power efficiency than lead-acid batteries.
- **Maintenance-free design**  
No need for daily checks and water re-fills. This reduces the risk of operators damaging cells and reducing their lifetime. Needs a full charge each week to activate cell balancing.
- **No need for spare batteries or charging room**  
You can save both space and costs in multi-shift applications, maximising profitability.
- **Quick charge capabilities**  
Just 15 minutes is all your battery needs to keep your truck going for a few more hours. It only takes 1 to 2 hours to fully charge a completely discharged battery.
- **Higher sustained voltage**  
This gives more consistent lifting and driving performance — particularly noticeable towards the end of a shift.
- **Multiple safety features**  
This includes circuit protection, deepdischarge and overcharge protection, and individual cell temperature and voltage monitoring.
- **On-the-go performance and monitoring**  
The system's integrated monitoring system has an easy-to-read display unit.
- **Wide choice of battery and charger capacities**  
The most suitable power supply can be matched to the exact requirements of a specific application.



**Clean Li-ion batteries are ideal for sensitive environments such as those in the food or packaging industries.**

**Fully integrated Li-ion battery**

Features a sophisticated CANbus communication and an automatic ON/OFF synchronization between battery and truck. Battery level, notifications and alarms are integrated into the truck display, to secure clear and easy overview for the truck operator.

**For more information on Li-ion please visit our website**



[mft2.eu/ion](http://mft2.eu/ion)

# VDI - PERFORMANCE & DIMENSIONS

CHARACTERISTICS				Mitsubishi Forklift Trucks	Mitsubishi Forklift Trucks	Mitsubishi Forklift Trucks	Mitsubishi Forklift Trucks	Mitsubishi Forklift Trucks	Mitsubishi Forklift Trucks
1.1	Manufacturer			FB14N2T	FB16CN2T	FB16N2T	FB18CN2T	FB18N2T	FB20N2T
1.2	Manufacturer's model designation			Electric	Electric	Electric	Electric	Electric	Electric
1.3	Power source: (battery, diesel, LP gas, petrol)			Seated	Seated	Seated	Seated	Seated	Seated
1.4	Operator type: pedestrian, (operator)-standing, -seated			1400	1600	1600	1800	1800	2000
1.5	Load capacity	Q	kg	500	500	500	500	500	500
1.6	Load center distance	c	mm	343	343	343	343	343	358
1.8	Load distance, axle to fork face	x	mm	1320	1320	1428	1320	1428	1428
1.9	Wheelbase	y	mm						
WEIGHT									
2.1	Truck weight, without load / including battery (simplex mast, lowest lift height)		kg	2790	2966	2949	3156	3119	3342
2.2	Axle loading with maximum load, front / rear (simplex mast, lowest lift height)		kg	3688 / 502	4015 / 551	4020 / 529	4351 / 605	4333 / 586	4711 / 631
2.3	Axle loading without load, front / rear (simplex mast, lowest lift height)		kg	1394 / 1396	1393 / 1573	1476 / 1474	1401 / 1754	1471 / 1649	1509 / 1833
WHEELS, DRIVE TRAIN									
3.1	Tyres: V=solid, L=pneumatic, SE=solid pneumatic - front / rear			SE	SE	SE	SE	SE	SE
3.2	Tyre dimensions, front			18 x 7-8	18 x 7-8	18 x 7-8	18 x 7-8	18 x 7-8	200 / 50-10
3.3	Tyre dimensions, rear			140 / 55-9	140 / 55-9	140 / 55-9	140 / 55-9	140 / 55-9	140 / 55-9
3.5	Number of wheels, front / rear (x=driven)			2 x / 2	2 x / 2	2 x / 2	2 x / 2	2 x / 2	2 x / 2
3.6	Truck width (center of tyres), front	b10	mm	930	930	930	930	930	938
3.7	Truck width (center of tyres), rear	b11	mm	174	174	174	174	174	174
DIMENSIONS									
4.1	Mast tilt, forwards / backwards	α/β	°	5 / 7.5	5 / 7.5	5 / 7.5	5 / 7.5	5 / 7.5	5 / 7.5
4.2	Height with mast lowered (see tables)	h1	mm	2125	2125	2125	2125	2125	2125
4.3	Free lift (see tables)	h2	mm	80	80	80	80	80	80
4.4	Lift height (see tables)	h3	mm	3290	3290	3290	3290	3290	3290
4.5	Overall height with mast raised	h4	mm	4335	4335	4335	4335	4335	4335
4.7	Height to top of overhead guard	h6	mm	2050	2050	2050	2050	2050	2050
4.8	Seat height	h7	mm	1035	1035	1035	1035	1035	1035
4.12	Tow coupling height	h10	mm	540	540	540	540	540	540
4.19	Overall length	l1	mm	2996	2996	3104	2996	3104	3119
4.20	Length to fork face (includes fork thickness)	l2	mm	1846	1846	1954	1846	1954	1969
4.21	Overall width	b1/b2	mm	1090	1090	1090	1090	1090	1140
4.22	Fork dimensions (thickness, width, length)	s / e / l	mm	35 x 100 x 1150	35 x 100 x 1150	35 x 100 x 1150	35 x 100 x 1150	35 x 100 x 1150	35 x 100 x 1150
4.23	Fork carriage to DIN 15 173 A/B/no			2A	2A	2A	2A	2A	2A
4.24	Fork carriage width	b3	mm	920	920	920	920	920	920
4.31	Ground clearance under mast, with load	m1	mm	95	95	95	95	95	95
4.32	Ground clearance at center of wheelbase, with load (forks lowered)	m2	mm	95	95	95	95	95	95
4.33	Working aisle width with 1000 x 1200 mm pallets, crosswise	Ast	mm	3173	3173	3281	3173	3281	3295
4.34a	Working aisle width with 800 x 1200 mm pallets, lengthwise	Ast	mm	3296	3296	3404	3296	3404	3419
4.35	Turning circle radius	Wa	mm	1502	1502	1610	1502	1610	1610
4.36	Minimum distance between centers of rotation	b13	mm	0	0	0	0	0	0
PERFORMANCE									
5.1	Travel speed, with / without load		km/h	16 / 16	16 / 16	16 / 16	16 / 16	16 / 16	16 / 16
5.2	Lifting speed, with / without load		m/s	0.55 / 0.62	0.52 / 0.62	0.52 / 0.62	0.46 / 0.62	0.46 / 0.62	0.62 / 0.42
5.3	Lowering speed, with / without load		m/s	0.56 / 0.56	0.56 / 0.56	0.56 / 0.56	0.56 / 0.56	0.56 / 0.56	0.56 / 0.56
5.5	Rated drawbar pull, with / without load		N	4900 / 5200	4900 / 5200	4900 / 5200	4800 / 5100	4800 / 5100	4700 / 5100
5.6	Maximum drawbar pull, with / without load (5 min short duty)		N	15000 / 15300	14900 / 15200	14900 / 15200	14900 / 15200	14900 / 15200	14800 / 15200
5.7	Gradeability, with / without load		%	16 / 26	15 / 25	15 / 25	13 / 23	13 / 23	12 / 21
5.8	Maximum gradeability, with / without load		%	27 / 35	27 / 35	27 / 35	26 / 35	26 / 35	24 / 35
5.9	Acceleration time (10 metres) with / without load		s	4.0 / 3.8	4.1 / 3.8	4.1 / 3.8	4.2 / 3.8	4.2 / 3.8	4.3 / 3.9
5.10	Service brakes (mechanical / hydraulic / electric / pneumatic)			Electric	Electric	Electric	Electric	Electric	Electric
ELECTRIC MOTORS									
6.1	Drive motor capacity (60 min. short duty)		kW	2 x 5.5	2 x 5.5	2 x 5.5	2 x 5.5	2 x 5.5	2 x 5.5
6.2	Lift motor output at 15% duty factor		kW	10	10	10	10	10	10
6.3	Battery to DIN 43 531 / 35 / 36 A/B/C/no			DIN 43531 A/no	DIN 43531 A/no	DIN 43531 A/no	DIN 43531 A/no	DIN 43531 A/no	DIN 43531 A/no
6.4	Battery voltage/capacity at 5-hour discharge		V/Ah	500-625	500-625	625-750	500-625	625-750	625-750
6.5	Battery weight		kg	679	679	812	679	812	812
6.6a	Energy consumption according to EN 16796		kWh/h	3.7	3.9	3.9	4.2	4.2	4.5
MISCELLANEOUS									
8.1	Type of drive control			AC	AC	AC	AC	AC	AC
10.1	Maximum operating pressure for attachments		bar	210	210	210	210	210	210
10.2	Oil flow for attachments		l/min	30	30	30	30	30	30
10.7	Noise level, value at operator's ear (EN 12053)		dB(A)	65	65	65	65	65	65
10.8	Towing coupling design / DIN type, ref.			DIN15170-H	DIN15170-H	DIN15170-H	DIN15170-H	DIN15170-H	DIN15170-H

**EDIA EM**

**ELECTRIC  
COUNTERBALANCE**

**FB14 - 20(C)N2T  
Series**

**3 wheel models**  
1.4 - 2.0 tonnes



# MAST PERFORMANCE AND CAPACITY

EDIA EM

## FB14 - 20(C)N2T Series

### 3 wheel models



MAST TYPE	FB14-20(C)N2T						FB14N2T	FB16CN2T	FB18CN2T	FB16N2T	FB18N2T	FB20N2T	
	h3 mm	h1 mm	h4 mm	h2 / h5 mm	tilt angle fwd / rew degrees		Q@ c=500 mm kg	Q@ c=500 mm kg	Q@ c=500 mm kg	Q@ c=500 mm kg	Q@ c=500 mm kg	Q@ c=500 mm kg	
					STD	CABIN							
SIMPLEX	2000**	1480*	3045	80	5 / 6	N.A.	1400	1600	1800	1600	1800	2000	
	2560**	1760*	3605	80	5 / 6	5 / 5	1400	1600	1800	1600	1800	2000	
	2760**	1860*	3805	80	5 / 7.5	5 / 6	1400	1600	1800	1600	1800	2000	
	3000	1980*	4045	80	5 / 7.5	5 / 6	1400	1600	1800	1600	1800	2000	
	3290	2125	4335	80	5 / 7.5	5 / 7.5	1400	1600	1800	1600	1800	2000	
	3530**	2245	4575	80	5 / 7.5	5 / 7.5	1400	1600	1800	1600	1800	2000	
	3720	2385	4765	80	5 / 7.5	5 / 7.5	1400	1600	1800	1600	1800	2000	
	4090	2570	5135	80	5 / 7.5	5 / 7.5	1400	1600	1800	1600	1800	2000	
	4480	2775	5525	80	5 / 5	5 / 5	1350	1550	1750	1575	1775	2000	
	5000	3035	6045	80	5 / 5	5 / 5	1300	1475	1675	1525	1700	1925	
DUPLX	2800**	1880*	3845	835	5 / 6	5 / 6	1400	1600	1800	1600	1800	2000	
	3000	1980*	4045	935	5 / 6	5 / 6	1400	1600	1800	1600	1800	2000	
	3295	2125	4340	1080	5 / 6	5 / 6	1400	1600	1800	1600	1800	2000	
	3515**	2245	4560	1200	5 / 6	5 / 6	1400	1600	1800	1600	1800	2000	
	3700	2385	4745	1340	5 / 6	5 / 6	1400	1600	1800	1600	1800	2000	
	4030	2570	5075	1525	5 / 6	5 / 6	1350	1550	1750	1575	1775	2000	
	TRIPLEX	3710	1780*	4755	735	5 / 6	5 / 3.5	1400	1600	1800	1600	1800	2000
		4010	1880*	5055	835	5 / 6	5 / 3.5	1400	1600	1800	1600	1800	2000
		4310	1980*	5355	935	5 / 6	5 / 5	1350	1600	1750	1600	1800	2000
		4750	2125	5795	1080	5 / 6	5 / 5	1300	1600	1700	1550	1800	2000
5090		2245	6135	1200	5 / 3.5	5 / 3.5	1275	1450	1650	1550	1750	1925	
5490		2385	6535	1340	5 / 3.5	5 / 3.5	1225	1400	1650	1500	1700	1900	
5990		2570	7035	1525	5 / 3.5	5 / 3.5	1175	1350	1600	1400	1600	1750	
6490		2830	7535	1785	5 / 3.5	5 / 3.5	1125	1350	1350	1350	1400	1650	
7000	3035	8045	1990	5 / 3.5	5 / 3.5	1100	1100	1100	1100	1100	1350		

\* Lower than overhead guard \*\*CSM

BATTERY DIMENSIONS		14N2T	16CN2T	18CN2T	16N2T	18N2T	20N2T
Battery voltage	V	48	48	48	48	48	48
Capacity at a 5-hour discharge	Ah	500 / 625	500 / 625	500 / 625	625 / 750	625 / 750	625 / 750
Battery weight, Min.	kg	679 / 812	679 / 812	679 / 812	812 / 900	812 / 900	812 / 900
Battery weight, Max.	kg	1000 / 1000	1000 / 1000	1000 / 1000	1160 / 1160	1160 / 1160	1160 / 1160
BATTERY BOX DIMENSIONS							
Length	mm	522	522	522	630	630	630
Width	mm	830 / 1006	830 / 1006	830 / 1006	830 / 1006	830 / 1006	830 / 1006
Height	mm	627	627	627	627	627	627
BATTERY COMPARTMENT SIZE							
Length	mm	532	532	532	640	640	640
Width	mm	850 / 1018	850 / 1018	850 / 1018	850 / 1018	850 / 1018	850 / 1018
Height	mm	690 (660*)	690 (660*)	690 (660*)	690 (660*)	690 (660*)	690 (660*)

\*With battery exchange rolls

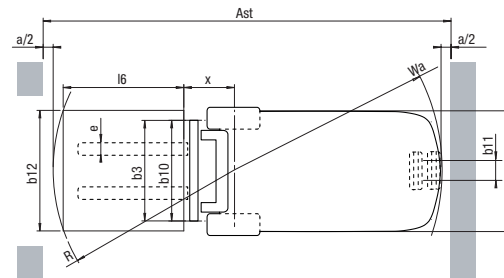
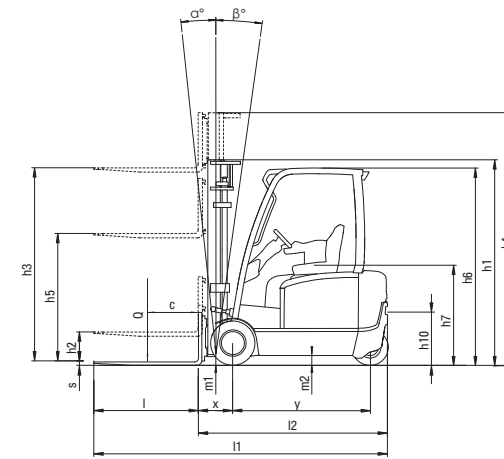

- Ast =  $Wa + R + a$
- Ast = Working aisle width
- Wa = Turning radius
- a = Safety clearance =  $2 \times 100$  mm
- R =  $\sqrt{(l6 + x)^2 + (b12 / 2)^2}$
- b12 = Pallet width (1200 mm)
- h1 = Height with mast lowered
- h2 = Standard free lift
- h3 = Lift height
- h4 = Height with mast raised
- h5 = Full free lift
- Q = Lifting capacity, rated load
- c = Load centre (distance)

### Capacities at various load centres

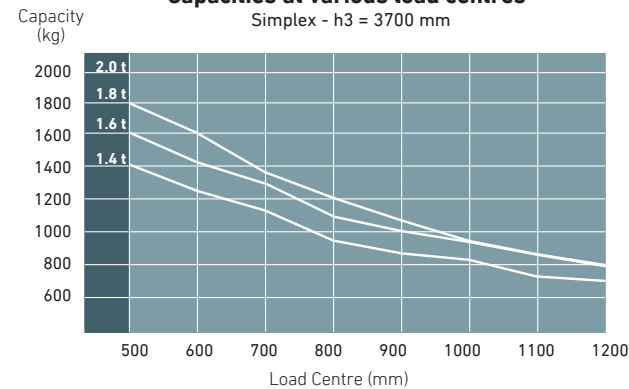

# VDI - PERFORMANCE & DIMENSIONS

CHARACTERISTICS				Mitsubishi Forklift Trucks	Mitsubishi Forklift Trucks	Mitsubishi Forklift Trucks	Mitsubishi Forklift Trucks	Mitsubishi Forklift Trucks
1.1	Manufacturer			FB16CN2	FB16N2	FB18CN2	FB18N2	FB20N2
1.2	Manufacturer's model designation			Electric	Electric	Electric	Electric	Electric
1.3	Power source: (battery, diesel, LP gas, petrol)			Seated	Seated	Seated	Seated	Seated
1.4	Operator type: pedestrian, (operator)-standing, -seated			1600	1600	1800	1800	2000
1.5	Load capacity	Q	kg	500	500	500	500	500
1.6	Load center distance	c	mm	343	343	343	343	358
1.8	Load distance, axle to fork face	x	mm	1394	1502	1394	1502	1502
1.9	Wheelbase	y	mm					
WEIGHT								
2.1	Truck weight, without load / including battery (simplex mast, lowest lift height)		kg	2944	2957	3114	3097	3287
2.2	Axle loading with maximum load, front / rear (simplex mast, lowest lift height)		kg	3990 / 554	4008 / 550	4311 / 603	4295 / 603	4668 / 620
2.3	Axle loading without load, front / rear (simplex mast, lowest lift height)		kg	1422 / 1522	1510 / 1448	1422 / 1692	1484 / 1613	1525 / 1762
WHEELS, DRIVE TRAIN								
3.1	Tyres: V=solid, L=pneumatic, SE=solid pneumatic - front / rear			SE	SE	SE	SE	SE
3.2	Tyre dimensions, front			18 x 7-8	18 x 7-8	18 x 7-8	18 x 7-8	200 / 50-10
3.3	Tyre dimensions, rear			16 x 6-8	16 x 6-8	16 x 6-8	16 x 6-8	16x6-8
3.5	Number of wheels, front / rear (x=driven)			2 x / 2	2 x / 2	2 x / 2	2 x / 2	2 x / 2
3.6	Truck width (center of tyres), front	b10	mm	930	930	930	930	938
3.7	Truck width (center of tyres), rear	b11	mm	898	898	898	898	898
DIMENSIONS								
4.1	Mast tilt, forwards / backwards	α/β	°	5 / 7.5	5/7.5	5/7.5	5/7.5	5/7.5
4.2	Height with mast lowered (see tables)	h1	mm	2125	2125	2125	2125	2125
4.3	Free lift (see tables)	h2	mm	80	80	80	80	80
4.4	Lift height (see tables)	h3	mm	3290	3290	3290	3290	3290
4.5	Overall height with mast raised	h4	mm	4335	4335	4335	4335	4335
4.7	Height to top of overhead guard	h6	mm	2050	2050	2050	2050	2050
4.8	Seat height	h7	mm	1035	1035	1035	1035	1035
4.12	Tow coupling height	h10	mm	520	520	520	520	520
4.19	Overall length	l1	mm	3152	3260	3152	3260	3275
4.20	Length to fork face (includes fork thickness)	l2	mm	2002	2110	2002	2110	2125
4.21	Overall width	b1/b2	mm	1090	1090	1090	1090	1140
4.22	Fork dimensions (thickness, width, length)	s / e / l	mm	35 x 100 x 1150	35 x 100 x 1150	35 x 100 x 1150	35 x 100 x 1150	35 x 100 x 1150
4.23	Fork carriage to DIN 15 173 A/B/no			2A	2A	2A	2A	2A
4.24	Fork carriage width	b3	mm	920	920	920	920	920
4.31	Ground clearance under mast, with load	m1	mm	95	95	95	95	95
4.32	Ground clearance at center of wheelbase, with load (forks lowered)	m2	mm	95	95	95	95	95
4.33	Working aisle width with 1000 x 1200 mm pallets, crosswise	Ast	mm	3333	3441	3333	3441	3455
4.34a	Working aisle width with 800 x 1200 mm pallets, lengthwise	Ast	mm	3456	3564	3456	3564	3579
4.35	Turning circle radius	Wa	mm	1662	1770	1662	1770	1770
4.36	Minimum distance between centers of rotation	b13	mm	0	0	0	0	0
PERFORMANCE								
5.1	Travel speed, with / without load		km/h	17 / 17	17 / 17	17 / 17	17 / 17	17 / 17
5.2	Lifting speed, with / without load		m/s	0.52 / 0.62	0.52 / 0.62	0.46 / 0.62	0.46 / 0.62	0.62 / 0.42
5.3	Lowering speed, with / without load		m/s	0.56 / 0.56	0.56 / 0.56	0.56 / 0.56	0.56 / 0.56	0.56 / 0.56
5.5	Rated drawbar pull, with / without load		N	4900 / 5200	4900 / 5200	4800 / 5100	4800 / 5100	4700 / 5100
5.6	Maximum drawbar pull, with / without load (5 min short duty)		N	14900 / 15200	15000 / 15300	14900 / 15200	14900 / 15200	14800 / 15200
5.7	Gradeability, with / without load		%	15 / 25	15 / 26	14 / 23	14 / 23	12 / 21
5.8	Maximum gradeability, with / without load		%	27 / 35	27 / 35	26 / 35	26 / 35	24 / 35
5.9	Acceleration time (10 metres) with / without load		s	4.1 / 3.8	4.0 / 3.8	4.2 / 3.8	4.2 / 3.8	3.9 / 4.4
5.10	Service brakes (mechanical / hydraulic / electric / pneumatic)			Electric	Electric	Electric	Electric	Electric
ELECTRIC MOTORS								
6.1	Drive motor capacity (60 min. short duty)		kW	2 x 5.5	2 x 5.5	2 x 5.5	2x5.5	2x5.5
6.2	Lift motor output at 15% duty factor		kW	10	10	10	10	10
6.3	Battery to DIN 43 531 / 35 / 36 A/B/C/no			DIN 43531 A/no	DIN 43531 A/no	DIN 43531 A/no	DIN 43531 A/no	DIN 43531 A/no
6.4	Battery voltage/capacity at 5-hour discharge		V/Ah	500-625	625-750	500-625	625-750	625-750
6.5	Battery weight		kg	679	679	679	812	812
6.6a	Energy consumption according to EN 16796		kWh/h	3.9	3.9	4.2	4.2	4.5
MISCELLANEOUS								
8.1	Type of drive control			AC	AC	AC	AC	AC
10.1	Maximum operating pressure for attachments		bar	210	210	210	210	210
10.2	Oil flow for attachments		l/min	30	30	30	30	30
10.7	Noise level, value at operator's ear (EN 12053)		dB(A)	65	65	65	65	65
10.8	Towing coupling design / DIN type, ref.			DIN15170-H	DIN15170-H	DIN15170-H	DIN15170-H	DIN15170-H

**EDIA EM**

**ELECTRIC  
COUNTERBALANCE**

**FB16 - 20(C)N2  
Series**

**4 wheel models**

1.6 - 2.0 tonnes



# MAST PERFORMANCE AND CAPACITY

**EDIA EM**

## FB16 - 20(C)N2 Series

4 wheel models



MAST TYPE	FB16-20(C)N2						FB16CN2	FB18CN2	FB16N2	FB18AN	FB20N2	
	h3 mm	h1 mm	h4 mm	h2 / h5 mm	tilt angle fwd / rew degrees		Q@ c=500 mm kg	Q@ c=500 mm kg	Q@ c=500 mm kg	Q@ c=500 mm kg	Q@ c=500 mm kg	
					STD	CABIN						
SIMPLEX	2000**	1480*	3045	80	5 / 6	N.A.	1600	1800	1600	1800	2000	
	2560**	1760*	3605	80	5 / 6	5 / 5	1600	1800	1600	1800	2000	
	2760**	1860*	3805	80	5 / 7.5	5 / 6	1600	1800	1600	1800	2000	
	3000	1980*	4045	80	5 / 7.5	5 / 6	1600	1800	1600	1800	2000	
	3290	2125	4335	80	5 / 7.5	5 / 7.5	1600	1800	1600	1800	2000	
	3530**	2245	4575	80	5 / 7.5	5 / 7.5	1600	1800	1600	1800	2000	
	3720	2385	4765	80	5 / 7.5	5 / 7.5	1600	1800	1600	1800	2000	
	4090	2570	5135	80	5 / 7.5	5 / 7.5	1600	1800	1600	1800	2000	
	4480	2775	5525	80	5 / 5	5 / 5	1600	1800	1600	1800	2000	
	5000	3035	6045	80	5 / 5	5 / 5	1525	1725	1600	1775	1950	
DUPLX	5500	3285	6545	80	5 / 3.5	5 / 3.5	1475	1650	1550	1725	1875	
	6000	3535	7045	80	5 / 3.5	5 / 3.5	1225	1225	1500	1500	1825	
	2800**	1880*	3845	835	5 / 6	5 / 6	1600	1800	1600	1800	2000	
	3000	1980*	4045	935	5 / 6	5 / 6	1600	1800	1600	1800	2000	
	3295	2125	4340	1080	5 / 6	5 / 6	1600	1800	1600	1800	2000	
	3515**	2245	4560	1200	5 / 6	5 / 6	1600	1800	1600	1800	2000	
	3700	2385	4745	1340	5 / 6	5 / 6	1600	1800	1600	1800	2000	
	4030	2570	5075	1525	5 / 6	5 / 6	1600	1800	1600	1800	2000	
	TRIPLEX	3710	1780*	4755	735	5 / 6	5 / 3.5	1600	1800	1600	1800	2000
		4010	1880*	5055	835	5 / 6	5 / 3.5	1600	1800	1600	1800	2000
4310		1980*	5355	935	5 / 6	5 / 5	1600	1800	1600	1800	2000	
4750		2125	5795	1080	5 / 6	5 / 5	1600	1750	1600	1800	2000	
5090		2245	6135	1200	5 / 3.5	5 / 3.5	1550	1700	1600	1750	1925	
5490		2385	6535	1340	5 / 3.5	5 / 3.5	1500	1600	1550	1700	1900	
5990		2570	7035	1525	5 / 3.5	5 / 3.5	1400	1600	1450	1625	1800	
6490		2830	7535	1785	5 / 3.5	5 / 3.5	1350	1400	1400	1400	1600	
7000	3035	8045	1990	5 / 3.5	5 / 3.5	1100	1100	1100	1100	1300		

\* Lower than overhead guard \*\*CSM

BATTERY DIMENSIONS		16CN2	18CN2	16N2	18N2	20N2
Battery voltage	V	48	48	48	48	48
Capacity at a 5-hour discharge	Ah	500 / 625	500 / 625	625 / 750	625 / 750	625 / 750
Battery weight, Min.	kg	679 / 812	679 / 812	812 / 900	812 / 900	812 / 900
Battery weight, Max.	kg	1000 / 1000	1000 / 1000	1160 / 1160	1160 / 1160	1160 / 1160
BATTERY BOX DIMENSIONS						
Length	mm	522	522	630	630	630
Width	mm	830 / 1006	830 / 1006	830 / 1006	830 / 1006	830 / 1006
Height	mm	627	627	627	627	627
BATTERY COMPARTMENT SIZE						
Length	mm	532	532	640	640	640
Width	mm	850 / 1018	850 / 1018	850 / 1018	850 / 1018	850 / 1018
Height	mm	690 (660*)	690 (660*)	690 (660*)	690 (660*)	690 (660*)

\*With battery exchange rolls

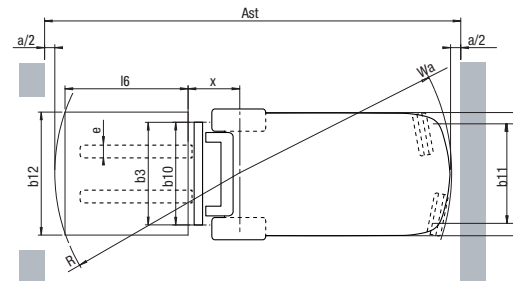
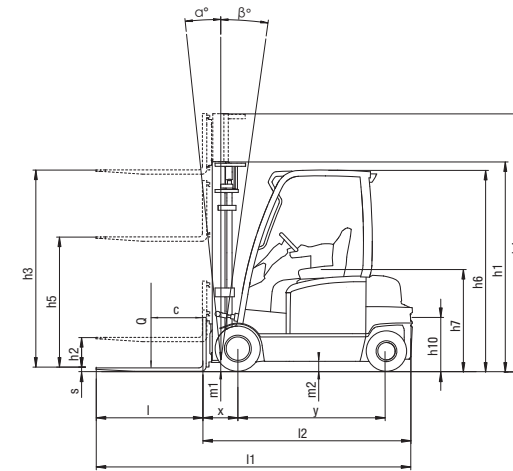

- Ast = Wa + R + a
- Ast = Working aisle width
- Wa = Turning radius
- a = Safety clearance = 2 x 100 mm
- R =  $\sqrt{(l6 + x)^2 + (b12 / 2 - b13)^2}$
- b12 = Pallet width (1200 mm)
- h1 = Height with mast lowered
- h2 = Standard free lift
- h3 = Lift height
- h4 = Height with mast raised
- h5 = Full free lift
- Q = Lifting capacity, rated load
- c = Load centre (distance)

### Capacities at various load centres

Simplex - h3 = 3700 mm

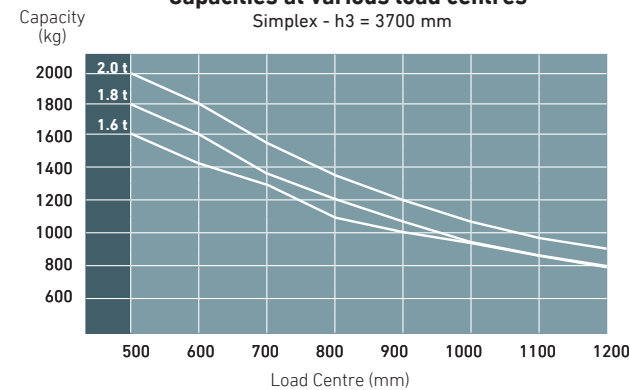



# STANDARD EQUIPMENT & OPTIONS

● = Standard  
● = Option

	FB14N2T	FB16CN2T	FB18CN2T	FB16N2T	FB18N2T	FB20N2T	FB16CN2	FB18CN2	FB16N2	FB18N2	FB20N2											
<b>GENERAL</b>						<b>3 WHEEL MODELS</b>						<b>4 WHEEL MODELS</b>										
3- and 4- Wheel chassis, 48 Volts, front wheel drive	●	●	●	●	●	●	●	●	●	●	●	●	●	●	●	●	●	●	●	●	●	●
Operator selectable economy or high performance modes ECO/PRO	●	●	●	●	●	●	●	●	●	●	●	●	●	●	●	●	●	●	●	●	●	●
Multifunctional colour display (hourmeter, BDI etc.)	●	●	●	●	●	●	●	●	●	●	●	●	●	●	●	●	●	●	●	●	●	●
Lift tilt interlock and hydraulic and drive interlock / PDS	●	●	●	●	●	●	●	●	●	●	●	●	●	●	●	●	●	●	●	●	●	●
Tilttable steering column	●	●	●	●	●	●	●	●	●	●	●	●	●	●	●	●	●	●	●	●	●	●
Full electrical brakes	●	●	●	●	●	●	●	●	●	●	●	●	●	●	●	●	●	●	●	●	●	●
Battery compartment side door and opening battery hood cover	●	●	●	●	●	●	●	●	●	●	●	●	●	●	●	●	●	●	●	●	●	●
SST (Seat Switch Timeout: all functions are disabled – truck enters 'stop mode' and park brake is automatically applied)	●	●	●	●	●	●	●	●	●	●	●	●	●	●	●	●	●	●	●	●	●	●
Basic overhead guard	●	●	●	●	●	●	●	●	●	●	●	●	●	●	●	●	●	●	●	●	●	●
Trucktool setup and diagnostics	●	●	●	●	●	●	●	●	●	●	●	●	●	●	●	●	●	●	●	●	●	●
Dual joysticks	●	●	●	●	●	●	●	●	●	●	●	●	●	●	●	●	●	●	●	●	●	●
Mini steering wheel	●	●	●	●	●	●	●	●	●	●	●	●	●	●	●	●	●	●	●	●	●	●
Ergologic Joystick	●	●	●	●	●	●	●	●	●	●	●	●	●	●	●	●	●	●	●	●	●	●
Rapid sideway battery exchange chassis (SWE)	●	●	●	●	●	●	●	●	●	●	●	●	●	●	●	●	●	●	●	●	●	●
Chassis-integrated roller bed (for battery SWE)	●	●	●	●	●	●	●	●	●	●	●	●	●	●	●	●	●	●	●	●	●	●
Special (RAL) colour for frame	●	●	●	●	●	●	●	●	●	●	●	●	●	●	●	●	●	●	●	●	●	●
<b>POWER SOURCE</b>						<b>3 WHEEL MODELS</b>						<b>4 WHEEL MODELS</b>										
Li-Ion battery*	●	●	●	●	●	●	●	●	●	●	●	●	●	●	●	●	●	●	●	●	●	●
Lead-acid battery	●	●	●	●	●	●	●	●	●	●	●	●	●	●	●	●	●	●	●	●	●	●
<b>HYDRAULIC</b>						<b>3 WHEEL MODELS</b>						<b>4 WHEEL MODELS</b>										
3 valve hydraulic fingertip control mounted on adjustable armrest	●	●	●	●	●	●	●	●	●	●	●	●	●	●	●	●	●	●	●	●	●	●
4th & 5th hydraulic options	●	●	●	●	●	●	●	●	●	●	●	●	●	●	●	●	●	●	●	●	●	●
Manual lever hydraulic control	●	●	●	●	●	●	●	●	●	●	●	●	●	●	●	●	●	●	●	●	●	●
Hydraulic accumulator for smoother load handling on rough surface	●	●	●	●	●	●	●	●	●	●	●	●	●	●	●	●	●	●	●	●	●	●
Low Noise Lift	●	●	●	●	●	●	●	●	●	●	●	●	●	●	●	●	●	●	●	●	●	●
<b>MAST, FORKS AND CARRIAGE</b>						<b>3 WHEEL MODELS</b>						<b>4 WHEEL MODELS</b>										
Load Backrest	●	●	●	●	●	●	●	●	●	●	●	●	●	●	●	●	●	●	●	●	●	●
Passive sway control for mast at high lifts	●	●	●	●	●	●	●	●	●	●	●	●	●	●	●	●	●	●	●	●	●	●
Simplex, Duplex or Triplex masts, from 3m to 7m	●	●	●	●	●	●	●	●	●	●	●	●	●	●	●	●	●	●	●	●	●	●
Forks 900mm - 2000mm	●	●	●	●	●	●	●	●	●	●	●	●	●	●	●	●	●	●	●	●	●	●
Sideshifter W920mm	●	●	●	●	●	●	●	●	●	●	●	●	●	●	●	●	●	●	●	●	●	●
Integrated Sideshifter W920mm	●	●	●	●	●	●	●	●	●	●	●	●	●	●	●	●	●	●	●	●	●	●
Integrated Fork Positioner with sideshift	●	●	●	●	●	●	●	●	●	●	●	●	●	●	●	●	●	●	●	●	●	●
Load weight indicator, in 50kg increments	●	●	●	●	●	●	●	●	●	●	●	●	●	●	●	●	●	●	●	●	●	●
Performance reduction from 2m to 3.5m mast (above standard)	●	●	●	●	●	●	●	●	●	●	●	●	●	●	●	●	●	●	●	●	●	●
<b>DRIVE AND LIFT CONTROLS</b>						<b>3 WHEEL MODELS</b>						<b>4 WHEEL MODELS</b>										
Variable speed control on all hydraulic functions	●	●	●	●	●	●	●	●	●	●	●	●	●	●	●	●	●	●	●	●	●	●
Curve control	●	●	●	●	●	●	●	●	●	●	●	●	●	●	●	●	●	●	●	●	●	●
Armrest direction control	●	●	●	●	●	●	●	●	●	●	●	●	●	●	●	●	●	●	●	●	●	●
Electronic differential lock	●	●	●	●	●	●	●	●	●	●	●	●	●	●	●	●	●	●	●	●	●	●
Automatic tilt centering via the F2 button on fingertip controller	●	●	●	●	●	●	●	●	●	●	●	●	●	●	●	●	●	●	●	●	●	●
Tilt centering second function. Two pcs. of angle memories	●	●	●	●	●	●	●	●	●	●	●	●	●	●	●	●	●	●	●	●	●	●
Forward-reverse direction selection lever on steering column	●	●	●	●	●	●	●	●	●	●	●	●	●	●	●	●	●	●	●	●	●	●
Dual pedal system - forward and reverse	●	●	●	●	●	●	●	●	●	●	●	●	●	●	●	●	●	●	●	●	●	●
Operator presence pedal	●	●	●	●	●	●	●	●	●	●	●	●	●	●	●	●	●	●	●	●	●	●

\* Li-ion battery option is available in selected regions.

## EDIA EM FB14-20(C)N2(T) Series

### ELECTRIC COUNTERBALANCE

1.4 – 2.0 tonnes



Multifunctional colour display (hourmeter, BDI etc.)



Dual pedal system - forward and reverse.



Manual lever hydraulic control.

# STANDARD EQUIPMENT & OPTIONS

● = Standard  
● = Option

	FB14N2T	FB16CN2T	FB18CN2T	FB16N2T	FB18N2T	FB20N2T	FB16CN2	FB18CN2	FB16N2	FB18N2	FB20N2
<b>ELECTRIC</b>	<b>3 WHEEL MODELS</b>						<b>4 WHEEL MODELS</b>				
LED working lights, 2 front and 1 rear	●	●	●	●	●	●	●	●	●	●	●
Automated reversing light	●	●	●	●	●	●	●	●	●	●	●
Automatic light switch	●	●	●	●	●	●	●	●	●	●	●
Amber strobe light	●	●	●	●	●	●	●	●	●	●	●
Road light kit	●	●	●	●	●	●	●	●	●	●	●
Electronic back-up smart alarm	●	●	●	●	●	●	●	●	●	●	●
"Blue Point" safety light, located rear and/or front	●	●	●	●	●	●	●	●	●	●	●
Red line safety lights, located on the sides	●	●	●	●	●	●	●	●	●	●	●
Pin code access	●	●	●	●	●	●	●	●	●	●	●
5V USB connector output 2x 2.5A (max. 4.4A)	●	●	●	●	●	●	●	●	●	●	●
240W, 12V Power supply for accessories	●	●	●	●	●	●	●	●	●	●	●
<b>OHG AND CABIN</b>	<b>3 WHEEL MODELS</b>						<b>4 WHEEL MODELS</b>				
Grammer MSG65 vinyl with seat belt switch	●	●	●	●	●	●	●	●	●	●	●
Grammer MSG65 or MSG75 with options vinyl / cloth / heater / backrest extension / Armrest (MSG65)	●	●	●	●	●	●	●	●	●	●	●
Swivel seat	●	●	●	●	●	●	●	●	●	●	●
Plexi roof cover	●	●	●	●	●	●	●	●	●	●	●
Panel cabin: Front screen with wiper + roof with crane opening	●	●	●	●	●	●	●	●	●	●	●
Panel cabin: Economy. Front screen without wiper, plexi roof cover	●	●	●	●	●	●	●	●	●	●	●
Panel cabin steel doors	●	●	●	●	●	●	●	●	●	●	●
Panel cabin rear screen	●	●	●	●	●	●	●	●	●	●	●
PVC doors	●	●	●	●	●	●	●	●	●	●	●
Heater for cabin	●	●	●	●	●	●	●	●	●	●	●
Interior package, including radio with speakers, roof lining, reading light.	●	●	●	●	●	●	●	●	●	●	●
Deluxe cabin, including wind screen with wiper, roof, steel doors, heater and interior lining.	●	●	●	●	●	●	●	●	●	●	●
Rear view mirror, Basic / Outside / Wide view	●	●	●	●	●	●	●	●	●	●	●
List bracket - A4	●	●	●	●	●	●	●	●	●	●	●
Storage plastic locker	●	●	●	●	●	●	●	●	●	●	●
Sun visor	●	●	●	●	●	●	●	●	●	●	●
Accessory rack	●	●	●	●	●	●	●	●	●	●	●
RAM-Mounts dummy, D-series	●	●	●	●	●	●	●	●	●	●	●
RAM-Mounts computer rack, C-series	●	●	●	●	●	●	●	●	●	●	●
RAM-Mounts scanner rack, C-series	●	●	●	●	●	●	●	●	●	●	●
Powder fire extinguisher	●	●	●	●	●	●	●	●	●	●	●
Narrow overhead guard for drive in racking	●	●	●	●	●	●	●	●	●	●	●
<b>TYRES</b>	<b>3 WHEEL MODELS</b>						<b>4 WHEEL MODELS</b>				
Solid pneumatic tyres	●	●	●	●	●	●	●	●	●	●	●
Solid non-marking tyres	●	●	●	●	●	●	●	●	●	●	●
<b>ENVIRONMENT</b>	<b>3 WHEEL MODELS</b>						<b>4 WHEEL MODELS</b>				
Hot area hydraulic oil, VG46	●	●	●	●	●	●	●	●	●	●	●
Cold area hydraulic oil, VG15	●	●	●	●	●	●	●	●	●	●	●
Hydraulic oil food grade	●	●	●	●	●	●	●	●	●	●	●
Bio grade oil	●	●	●	●	●	●	●	●	●	●	●
Cold store option, (to -35C)	●	●	●	●	●	●	●	●	●	●	●

## EDIA EM FB14-20(C)N2(T) Series

### ELECTRIC COUNTERBALANCE

1.4 – 2.0 tonnes



LED working lights, 2 front and 1 rear.



Blue point and red line safety lights



Deluxe cabin

# WHEN RELIABILITY IS EVERYTHING...



**EDiA**  
THE ELECTRIC DIAMOND

The family name EDiA appears proudly on our award-winning range of electric forklift trucks.

The reputation that Mitsubishi Forklift Trucks enjoys for endurance and reliability has likened them to the quality and enduring value of a diamond.

Like any product bearing the "MITSUBISHI" name our materials handling equipment benefits from the tremendous heritage, huge resources and cutting-edge technology of one of the world's largest corporations – Mitsubishi Heavy Industries Group.

Engineering spacecraft, jet planes, power plants and more, MHI specialises in those technologies where performance, dependability and superiority decide your success or failure...

So when we promise you quality, reliability and value for money, you know it's a guarantee we have the power to deliver.

That's why every model in our award-winning and comprehensive range of lift trucks and warehouse equipment is built to a high specification – to ensure it keeps working for you. Day after day. Year after year. Whatever the job. Whatever the conditions.

## YOU'LL NEVER WORK ALONE

As your local authorised dealer, we are here to keep your trucks working – through our extensive experience, our technical excellence and our commitment to customer care.

We are your local experts, backed by efficient channels to the entire organisation of Mitsubishi Forklift Trucks.

No matter where you are, we are close by – with the capability to meet your needs.

Discover how Mitsubishi Forklift Trucks give you more from your local authorised dealer or when you visit our website [www.mitforklift.com](http://www.mitforklift.com)

Performance specifications may vary depending on standard manufacturing tolerances, vehicle condition, types of tyres, floor or surface conditions, applications or operating environment. Trucks may be shown with non-standard options. Specific performance requirements and locally available configurations should be discussed with your distributor of Mitsubishi forklift trucks. We follow a policy of continual product improvement. For this reason, some materials, options and specifications could change without notice.

[info@mitforklift.com](mailto:info@mitforklift.com)

CESM2237 (08/22) © 2022 MLE



Mitsubishi Logisnext Europe B.V.  
Hefbrugweg 77, 1332 AM Almere  
The Netherlands  
Tel: +31 (0)36 5494 411



[mft2.eu/fb](http://mft2.eu/fb)



[mft2.eu/apps](http://mft2.eu/apps)



[mft2.eu/youtube](http://mft2.eu/youtube)



[mft2.eu/facebook](http://mft2.eu/facebook)

